

DR-Anchor

Lifting System

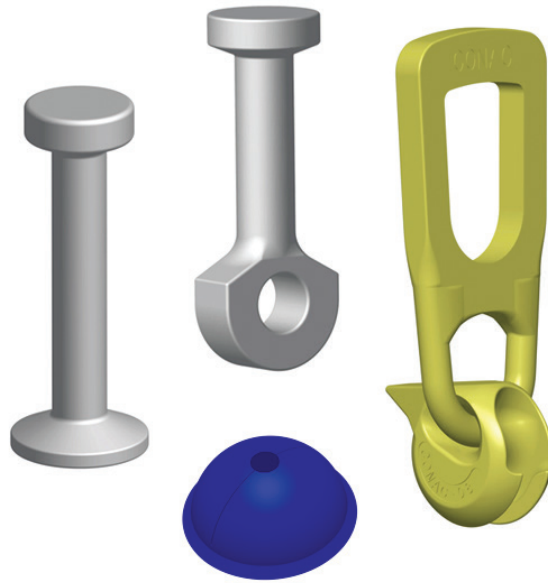

Economical and effective method for backstripping or face lifting in tension. The system code is stamped on the head of each anchor to match with the correct lifting unit.

DR System

DR Anchors

Economical and effective method for backstripping or face lifting in tension. The system code is stamped on the head of each anchor to match with the correct lifting unit. Stocked in hot dip galvanized; mill finish available on request.

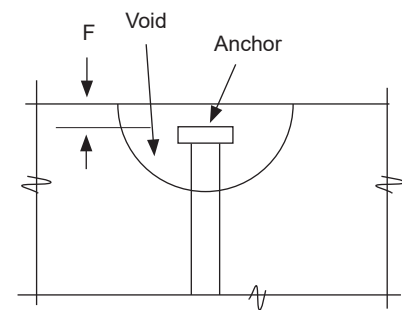
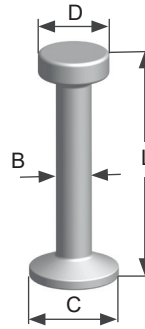

ITEM CODE	SYSTEM CODE	LENGTH (L)	SWL TENSION (LBS)	EDGE DISTANCE	BODY DIAMETER (B)	BASE DIAMETER (C)	HEAD DIAMETER (D)	HEAD RECESS (F)
		1-TON						
DRA01055HG	1.3	2-3/16"	2020	3-3/4"	3/8"	1"	3/4"	3/8"
DRA01065HG	1.3	2-9/16"	2070	4-1/2"	3/8"	1"	3/4"	3/8"
DRA01085HG	1.3	3-3/8"	2070	5-3/4"	3/8"	1"	3/4"	3/8"
DRA01120HG	1.3	4-11/16"	2070	7-3/4"	3/8"	1"	3/4"	3/8"
DRA01200HG	1.3	8"	2070	14-3/4"	3/8"	1"	3/4"	3/8"
		2-TON						
DRA02045HG	2.5	1-3/4"	1590	3-1/2"	9/16"	1-3/8"	1"	7/16"
DRA02070HG	2.5	2-3/4"	2850	4-3/4"	9/16"	1-3/8"	1"	7/16"
DRA02085HG	2.5	3-3/8"	3710	5-3/4"	9/16"	1-3/8"	1"	7/16"
DRA02120HG	2.5	4-11/16"	4060	7-3/4"	9/16"	1-3/8"	1"	7/16"
DRA02140HG	2.5	5-1/2"	4130	9"	9/16"	1-3/8"	1"	7/16"
DRA02170HG	2.5	6-11/16"	4130	10-3/4"	9/16"	1-3/8"	1"	7/16"
DRA02280HG	2.5	11"	4130	17"	9/16"	1-3/8"	1"	7/16"
		4-TON						
DRA04075HG	5	3"	3360	5-1/4"	3/4"	2"	1-7/16"	5/8"
DRA04095HG	5	3-3/4"	4580	6-1/2"	3/4"	2"	1-7/16"	5/8"
DRA04110HG	5	4-5/16"	5580	7-1/2"	3/4"	2"	1-7/16"	5/8"
DRA04120HG	5	4-11/16"	6280	8"	3/4"	2"	1-7/16"	5/8"
DRA04140HG	5	5-1/2"	7760	9-1/4"	3/4"	2"	1-7/16"	5/8"
DRA04160HG	5	6-5/16"	8260	10-1/4"	3/4"	2"	1-7/16"	5/8"
DRA04180HG	5	7-1/16"	8260	11-1/2"	3/4"	2"	1-7/16"	5/8"
DRA04240HG	5	9-7/16"	8260	15"	3/4"	2"	1-7/16"	5/8"
		8-TON						
DRA08120HG	10	4-11/16"	6200	7-3/4"	1-1/8"	2-5/8"	1-7/8"	5/8"
DRA08135HG	10	5-5/16"	7310	8-3/4"	1-1/8"	2-5/8"	1-7/8"	5/8"
DRA08150HG	10	5-15/16"	8460	9-3/4"	1-1/8"	2-5/8"	1-7/8"	5/8"
DRA08170HG	10	6-11/16"	10090	10-3/4"	1-1/8"	2-5/8"	1-7/8"	5/8"
DRA08220HG	10	8-7/8"	14540	13-3/4"	1-1/8"	2-5/8"	1-7/8"	5/8"
DRA08250HG	10	9-7/8"	16260	15-1/2"	1-1/8"	2-5/8"	1-7/8"	5/8"
DRA08340HG	10	13-3/8"	16260	21"	1-1/8"	2-5/8"	1-7/8"	5/8"
		16-TON						
DRA16250HG	20	9-7/8"	17270	15-1/2"	1-1/2"	3-7/8"	2-5/8"	5/8"
DRA16500HG	20	19-11/16"	31550	30"	1-1/2"	3-7/8"	2-5/8"	5/8"
		20-TON						
DRA20500HG	20	19-11/16"	40000	40"	1-1/2"	3-7/8"	2-5/8"	5/8"

Safe working loads based on approximate 4:1 safety factor in 5,000 psi normal weight concrete.

Eye Anchors

Forged Eye Anchors are primarily used in thin pannels utilizing rebar to extend the shear cone. Stocked in hot dip galvanized; mill finish available on request.

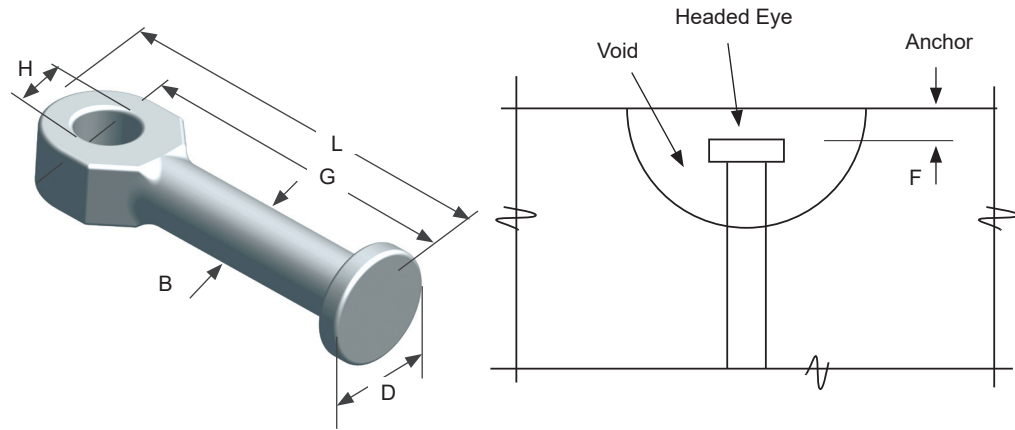

ITEM CODE	SYSTEM CODE	ANCHOR LENGTH (L)	BODY DIAMETER (B)	HEAD DIAMETER (D)	HEAD RECESS (F)	HOLE LOCATION (G)	HOLE DIAMETER (H)	SWL TENSION (LBS)	EDGE DISTANCE
		1-TON							
DRO1065HG	1.3	2-9/16"	3/8"	3/4"	3/8"	2-1/8"	13/32"	2070	3-3/4"
		2-TON							
DRO2090HG	2.5	3-5/8"	9/16"	1"	7/16"	3"	1/2"	4060	5-3/4"
		4-TON							
DRO4120HG	5	4-3/4"	3/4"	1-7/16"	5/8"	3-7/8"	3/4"	8260	6-1/2"
		8-TON							
DRO8180HG	10	7-1/16"	1-1/8"	1-7/8"	5/8"	6"	1"	16260	9-3/4"
		16-TON							
DRO16250HG	20	9-7/8"	1-1/2"	2-3/4"	5/8"	8"	1-7/16"	31550	12-1/2"

Safe working loads based on approximate 4:1 safety factor in 5,000 psi normal weight concrete.

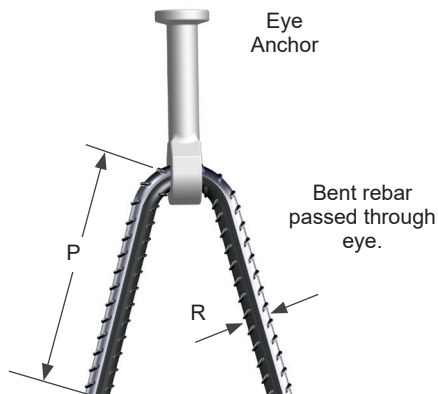

Note: Eye Anchors require use of bent rebar V through hole to develop tension capacity.

TENSION VEES			
NOMINAL SYS. CAPACITY	ANCHOR ITEM CODE	REQUIRED REBAR SIZE (R)	BENT REBAR LEG (P)
1 Ton	DRO1065	5/16"	10"
2 Ton	DRO2090	#3	12"
4 Ton	DRO4120	#5	12"
8 Ton	DRO8180	#6	24"
16 Ton	DRO16250	#8	43"

Magnetic Recess Formers

This steel body is turned from solid material and fitted with a high-performance magnetic system, providing a high-powered magnet for locating DR Anchors in steel forms.

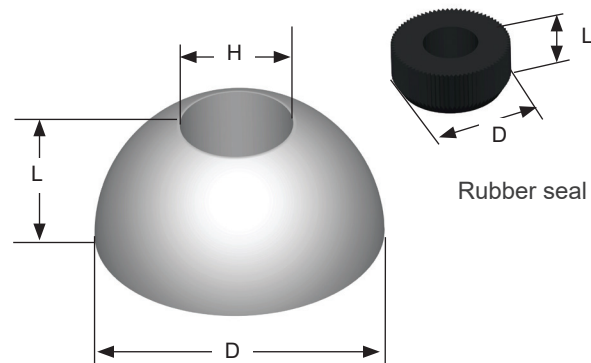

ITEM CODE	SYSTEM CODE	RECESS DIAMETER (D)	RECESS HEIGHT (L)	HOLE DIAMETER (H)	THREAD SIZE
KA13M	1.3	2-3/8"	1-1/8"	13/16"	M8
KA25M	2.5	2-7/8"	1-5/16"	1-1/8"	M12
KA50M	5	3-11/16"	1-5/8"	1-1/2"	M12
KA75M	10	4-3/4"	2-1/8"	1-7/8"	M12
			HEIGHT (L)	DIAMETER (D)	
KA13GM	Rubber Seal For Magnet		7/16"	13/16"	
KA25GM	Rubber Seal For Magnet		1/2"	1-3/16"	
KA50GM	Rubber Seal For Magnet		9/16"	1-1/2"	
KA75GM	Rubber Seal For Magnet		3-4"	1-15/16"	

Rubber Recess Formers

Used to Recess DR Anchors relative to the concrete surface. Each Rubber Recess Former requires one Wing Nut, Plate, and Stud Set to attach it to the form.

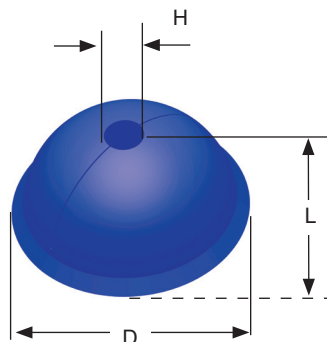

ITEM CODE	SYSTEM CODE	RECESS DIAMETER (D)	RECESS HEIGHT (L)	HOLE DIA. (H)
DRR01	1.3	2-5/16"	1-3/16"	3/8"
DRR02	2.5	2-7/8"	1-7/16"	9/16"
DRR04	5	3-11/16"	1-7/8"	3/4"
DRR08	10	4-5/8"	2-5/16"	1-1/8"
DRR16	20	6-1/2"	3"	1-1/2"

Steel Recess Former

Drilled and tapped to allow bolting directly to the form. Can be welded to certain types of forms where location is permanent.

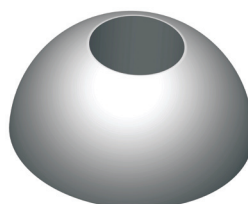

ITEM CODE	SYSTEM CODE	RECESS DIAM. X DEPTH
DRS01	1.3	2-5/16" X 1-3/16"

DR System



Wing Nut, Plate & Stud Sets

Used to hold the DR Rubber Recess Formers to the formwork.

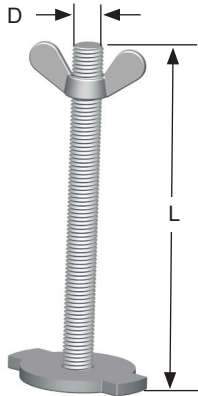

ITEM CODE	SYSTEM CODE	STUD DIA. (D)	STUD LENGTH (L)
DRW01A	1.3	M8	3-1/8"
DRW02A	2.5	M10	3-1/8"
DRW04A	5	M10	4"
DRW08A	10	M12	4"
DRW16A	20	M12	4"

DR Anchor Threaded Plates

Can be used with stud or bolt recess former to form.

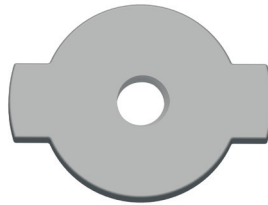

ITEM CODE	SYSTEM CODE	THREADS
DRWP01	1.3	M8
DRWP02	2.5	M10
DRWP04	5	M10
DRWP08	10	M10

Dr Anchor Plastic Caps

Protective caps attach to head of DR anchor to prevent debris from filling the recess.



ITEM #	SYSTEM CODE	DESCRIPTION
DRR01 CAP	1.3	DR-ANCHOR 1 TON PLASTIC CAP
DRR02 CAP	2.5	DR-ANCHOR 2 TON PLASTIC CAP
DRR04 CAP	5	DR-ANCHOR 4 TON PLASTIC CAP
DRR08 CAP	10	DR-ANCHOR 8 TON PLASTIC CAP

Dr-Anchor Lifting Units

For use with DR Anchors. Lifting Eye rotates on the anchor to the direction of load. The system Code is stamped on each unit to match with the correct anchor type. Available with bail or chain. Standard finish plated.

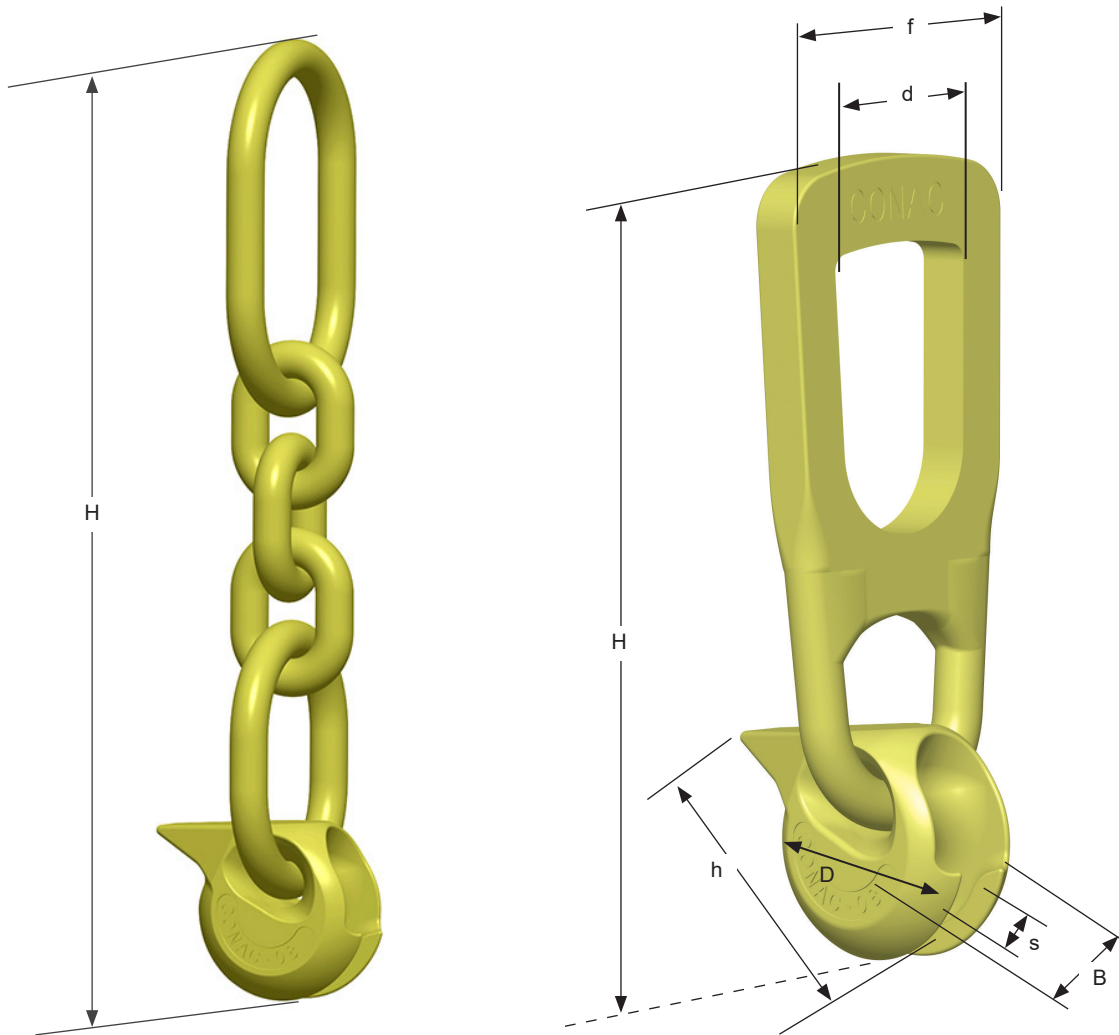

Standard (With Bail)

ITEM CODE	SYSTEM CODE (T)	SYSTEM CAPACITY (T)	HEAD DIA. (MM)	SHAFT DIA. (MM)	D	H	h	B	s	d	f	WEIGHT (LB/PC)
Lifting Eye 1T	1.3	1	19	10	52	200	73	32	11	45	72	2.18
Lifting Eye 2T	2	2	26	14	63	220	91	42	16	58	87	3.1
Lifting Eye 4T	5	4	36	20	82	275	111	57	22	68	116	7.08
Lifting Eye 8T	10	8	47	28	104	390	150	72	29	84	160	19.62
Lifting Eye 16T	20	16	69	39	153	520	210	109	41	115	187	48.4

Safe working loads based on 5:1 Safety Factor.

With Chain

ITEM CODE	SYSTEM CODE (T)	SYSTEM CAPACITY (T)	HEAD DIA. (MM)	SHAFT DIA. (MM)	D	H	h	B	s	d	f	WEIGHT (LB/PC)
SC3-2	2	2	26	14	63	381	91	42	16			4.18
SC3-4	5	4	36	20	82	444	111	57	22			9.52
SC3-8	10	8	47	28	104	660	150	72	29			24.84
SC3-20	20	16	69	39	153		210	109	41			53

Safe working loads based on 5:1 Safety Factor.

Operation Instructions For Lifting Eye

1. General

The CONAC Lifting Eye is a load lifting device. It grips the head of a DR anchor inside of the recess created by the CONAC Recess Formers. The bail is made from robust, hardened and tempered cast steel. The CONAC Lifting Eye meets the requirements of the "Safety regulations for lifting precast concrete units". Important references include but are not limited to: OSHA Part 1926 and ANSI 10.9.

2. Operating Instructions for the Conac Lifting Eye

1. Hold the CONAC Lifting Eye upside down such that the opening of the bail is placed directly on the anchor head (Figure 1).

2. Rotate the bail until the anchor head has reached the end of the channel (Figure 2). The lip of the bail should be entirely level with the surface of the concrete as shown in the figure.

*If the lip is not level, the anchor head is not completely inside the channel and further rotation of the bail is necessary. Failure to do this could cause the anchor head to bend.

3. The CONAC Lifting Eye can then be used for a straight pull (Figure 2) or for parallel/transversal shear pulls. For parallel or transversal shear pulls, the bail lip must point in the direction of the pull.

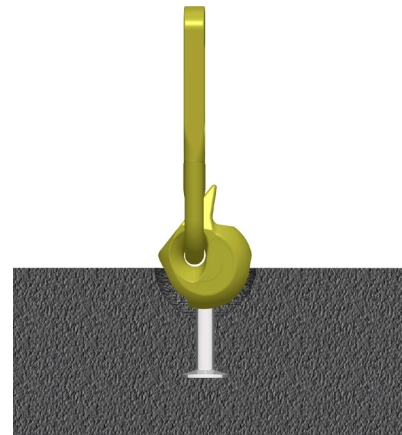

Figure 1

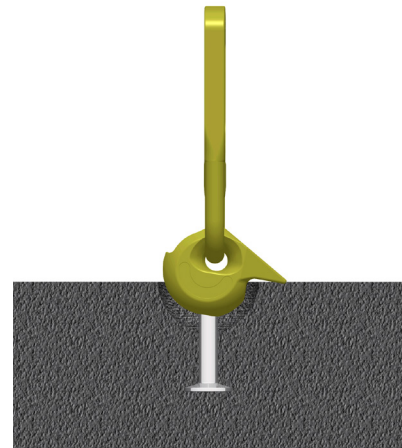

Figure 2

Warning: For traversal/parallel shear pull, the bail lip must point in the direction of the pull, as shown in Figure 4. If positioned incorrectly (Figure 5), the Lifting Eye can come loose.

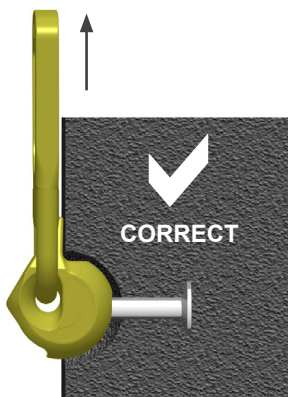

Figure 4

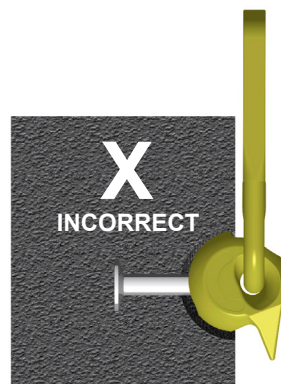

Figure 5

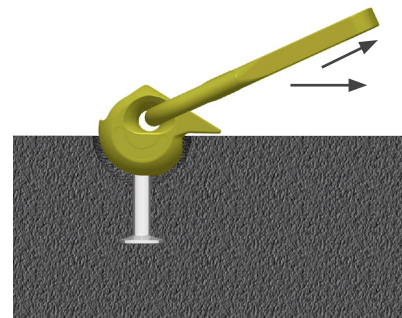

Figure 4

Warning: Do not allow the crane lines to form an angle less than 90 degrees during an edge lift application. This condition can bend the lifting eye bail and could lead to failure.

3. Identification

The identification meets the "Safety regulations for lifting precast concrete units" as follows:

Manufacturer	CONAC
Type	Lifting Eye
Size	e.g. 4T
Manufacture Year	e.g.20
Batch Number	e.g.1234

4. Care, Inspection And Maintenance Of Lifting Eyes

CONAC DR Anchor Lifting Eyes may become worn after extended use or may be damaged through misuse, overloading, or a number of other factors, any one of which may affect the Safe Working Load of the Lifting Eye.

Responsible users will establish a system of periodic inspections which should include the following:

1. Inspect for general condition and wear.
2. Ensure that the bail is free to rotate in all directions.
3. If the bail is bent or twisted, the Lifting Eye must be destroyed.
4. If the throat of the lifting body appears to be spread or deformed, the Lifting Eye must be destroyed.
5. If it appears that the Lifting Eye has been heated in any way, the Lifting Eye must be destroyed.

Destroy any unit that is worn, damaged, bent or twisted by cutting off the bail.
No repair or welding is permitted.

Maximum Working Load	1T	2T	4T	8T	16T
Maximum Channel Opening	12 mm	17 mm	23.6 mm	31 mm	43 mm

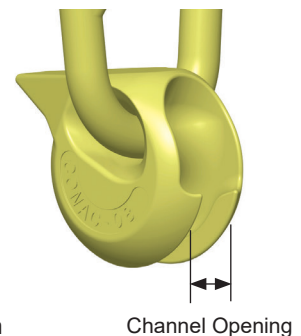

Warning: Before lifting, the Lifting Eye should be checked to ensure that it is fully engaged with the anchor. Lifting eyes and anchors from different manufacturers should not be used together. Failure to observe any safety recommendation can result in a service failure of the lifting system.

Warning: Do not modify, weld or alter in any way the Conac Lifting Eye.